

NOTICE

1. * Measures are reduced to below because the draft tolerance after GTA13/5 DIN16901-130;
2. Unmarked Draft 2°.

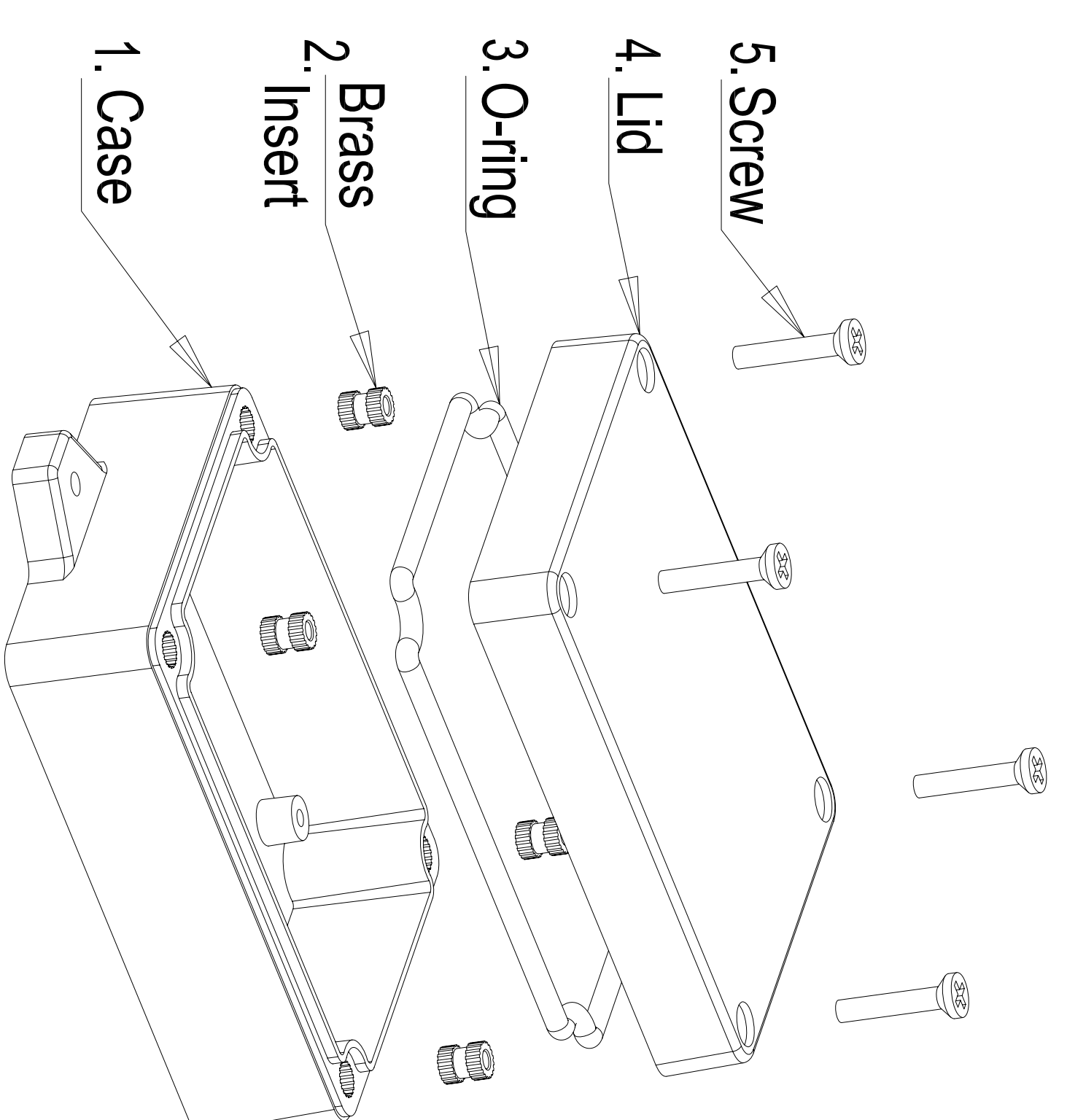

No.	Name	Qty.	Size	Material
5	Screw	4	M4X20 (DIN 965)	Stainless Steel
4	Lid	1	83X58X12	ABS
3	O-ring	1	Ø3X280	PU
2	Insert	4	M4X8	Brass
1	Case	1	108X58X22.5	ABS

Tolerances: DIN16901 - 130

Treatment:

Scale: Free

Volume: mm³
Weight: 0.262 Kg

Original Material:

ABS

Chinese Material:

FUXIN
Metal Processing Co., Ltd

Part Name :

FUP 083 X 058 X 033

Drawing Number :

FUP 083 X 058 X 033

Designer

Liu Junbin

2009.12.08

Technician

Sheet 1 of 1

Quality

department

Index (Customer)

REV

Name

Date

Index (FUXIN)

REV

Name

Date