

NOTICE
 1. * Measures are reduced to below because the draft tolerance after GTA13/5 DIN16901-130;
 2. Unmarked Draft 2°.

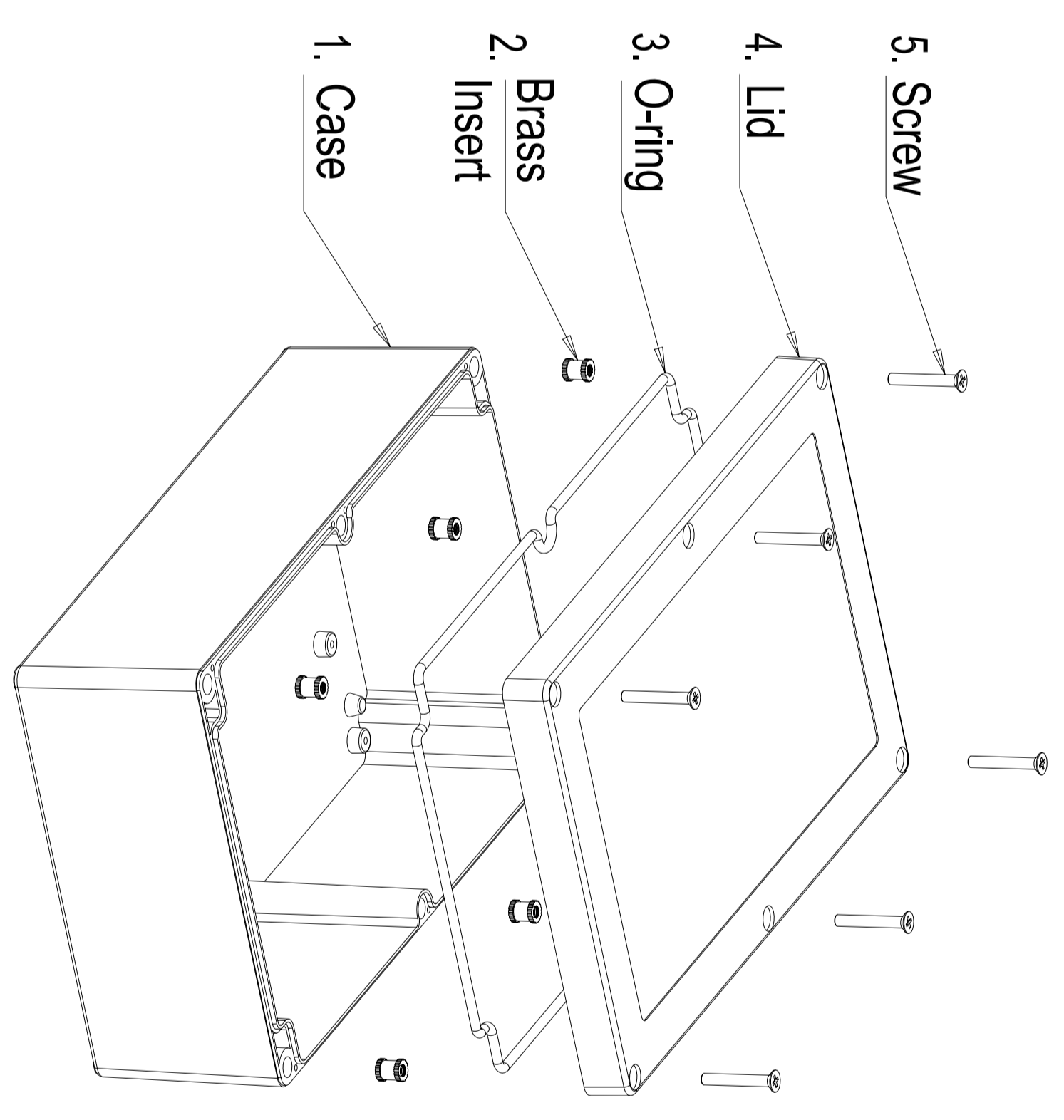

No.	Name	Qty.	Size	Material
5	Screw	6	M4X20 (DIN 965)	Stainless Steel
4	Lid	1	222X146X15	ABS
3	O-ring	1	Ø3X750	PU
2	Insert	6	M4X8	Brass
1	Case	1	222X146X48	ABS

Scale: Free
 Volume: mm³
 Weight: 0.447 Kg
 Original Material: ABS
 Chinese Material: ABS
 Tolerances: DIN16901 - 130

Index (Customer)	REV	Name	Date	Index (FUXIN)	REV	Name	Date



Metal Processing Co., Ltd

Part Name :

FUP 222 X 146 X 080

Drawing Number :

FUP 222 X 146 X 080

Designer: Liu Junbin
 Date: 2009.12.11
 Technician Quality department
 Sheet 1 of 1