

NOTICE

1. * Measures are reduced to below because the draft tolerance after GT/A13/5 DIN16901-130;
2. Unmarked Draft 2°.

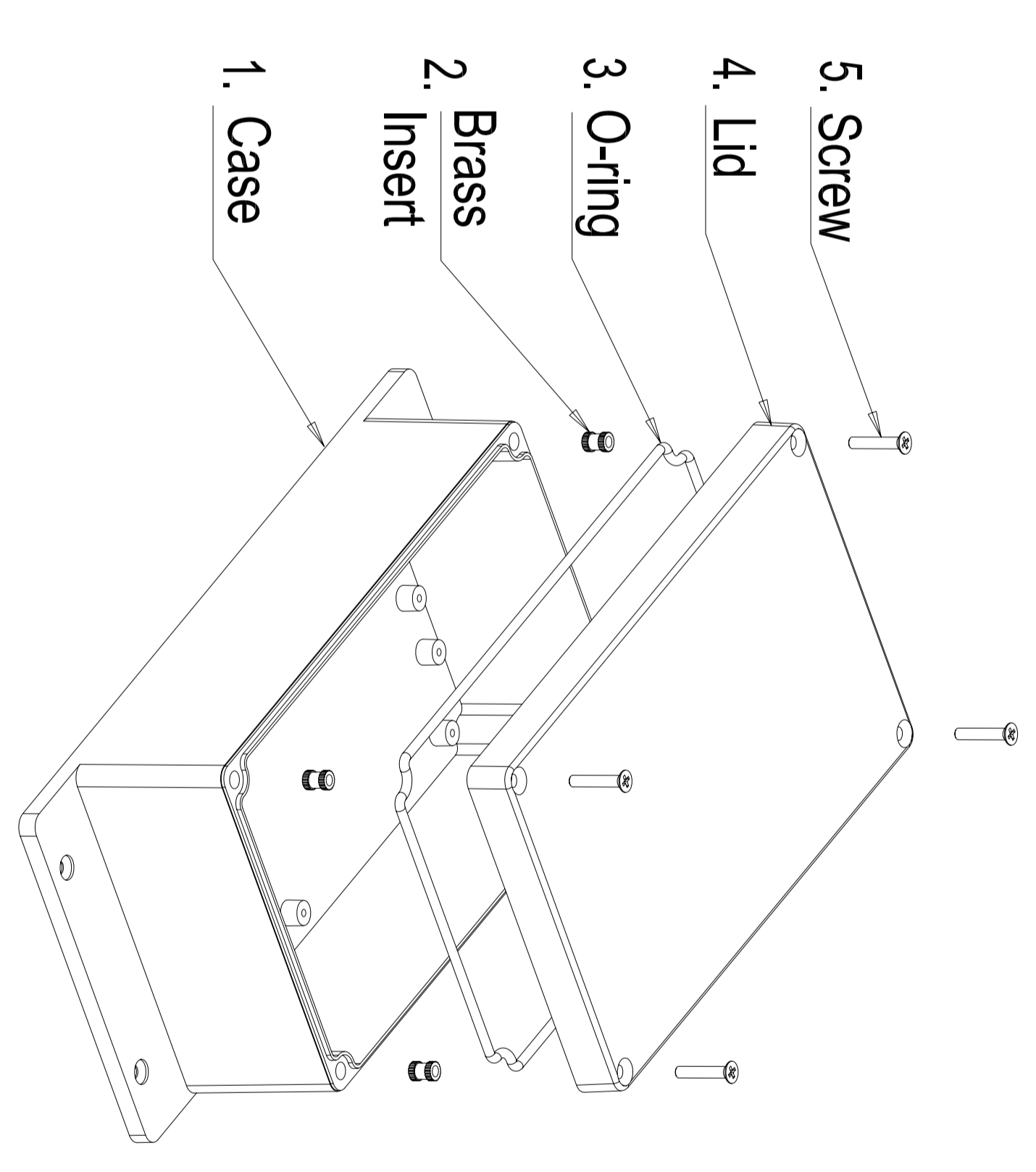

No.	Name	Qty.	Size	Material
5	Screw	4	M4X20 (DIN 965)	Stainless Steel
4	Lid	1	200X120X15	ABS
3	O-ring	1	Ø3X630	PU
2	Insert	4	M4X8	Brass
1	Case	1	200X120X61.5	ABS

Tolerances: DIN16901 - 130

Index (Customer)	REV	Name	Date	Index (FUXIN)	REV	Name	Date



Metal Processing Co., Ltd

Part Name :

FUP 200 X 120 X 075

Scale: Free
 Original Material: ABS
 Chinese Material:

Volume: mm³
 Weight: 0.35 Kg

Drawing Number :

FUP 200 X 120 X 075

Designer	Liu Junbin	2009.12.11
Technician		
Quality department		