

**NOTICE**  
 1. \* Measures are reduced to below because the draft tolerance after GTA13/5 DIN16901-130;  
 2. Unmarked Draft 2°.

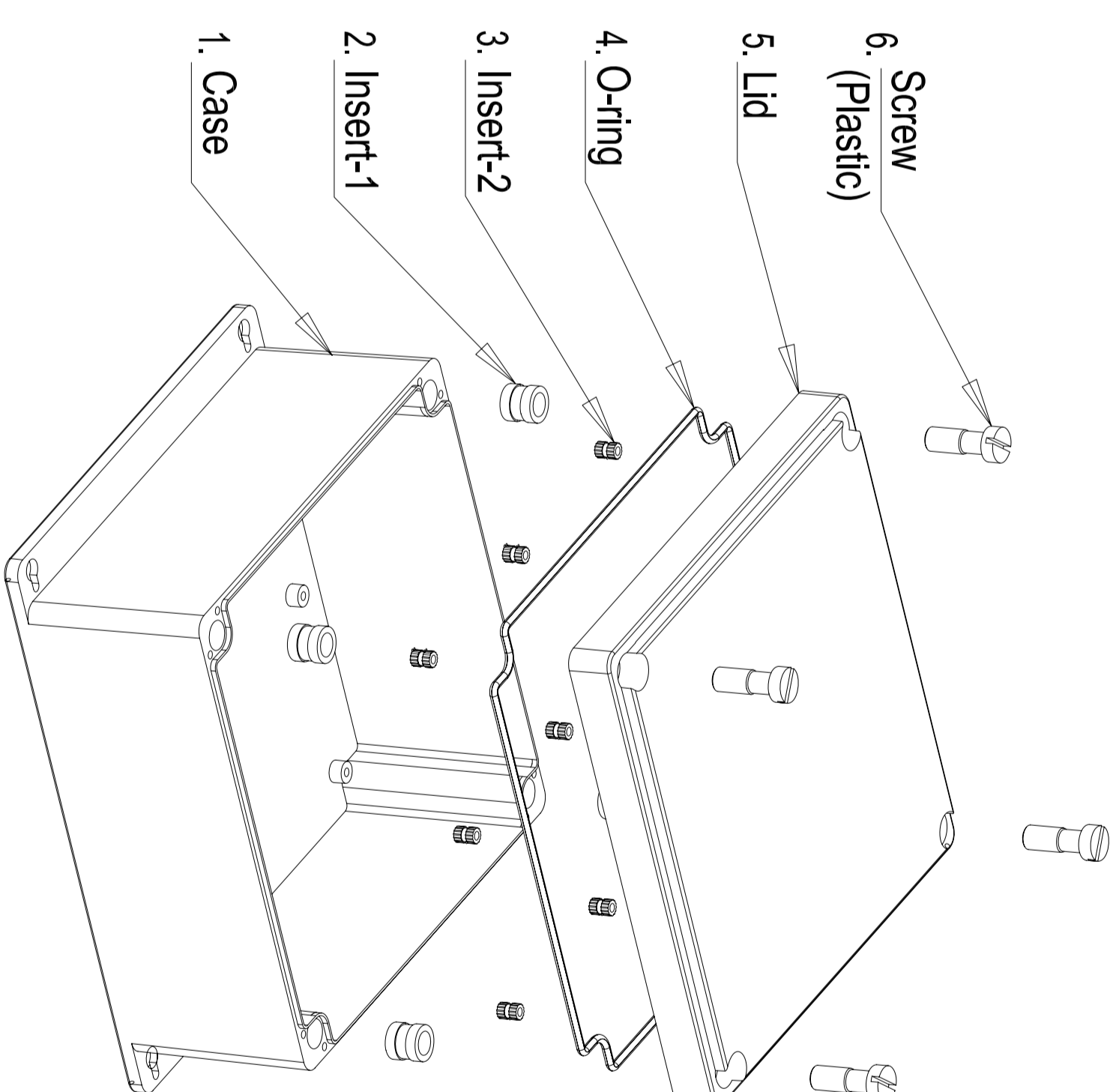

No.	Name	Qty.	Size	Material
6	Screw	4	M10X25	Plastic
5	Lid	1	193X188X22	ABS
4	O-ring	1	Ø3X750	PU
3	Insert-2	6	M4X8	Brass
2	Insert-1	4	M10X12.5	Brass
1	Case	1	226X188X80.5	ABS

Scale: Free  
 Original Material: ABS  
 Chinese Material: ABS  
 Volume: mm<sup>3</sup>  
 Weight: 0.86 Kg  
 Tolerances: DIN16901 - 130

Index (Customer)  
 REV  
 Name  
 Date

Index (FUXIN)  
 REV  
 Name  
 Date



Part Name :  
 FUP 190 X 190 X 100

Drawing Number :  
 FUP 190 X 190 X 100

Designer: Liu Junbin  
 Date: 2009.12.07  
 Sheet 1 of 1