

NOTICE
 1. * Measures are reduced to below because the draft tolerance after GTA13/5 DIN16901-130;
 2. Unmarked Draft 2°.

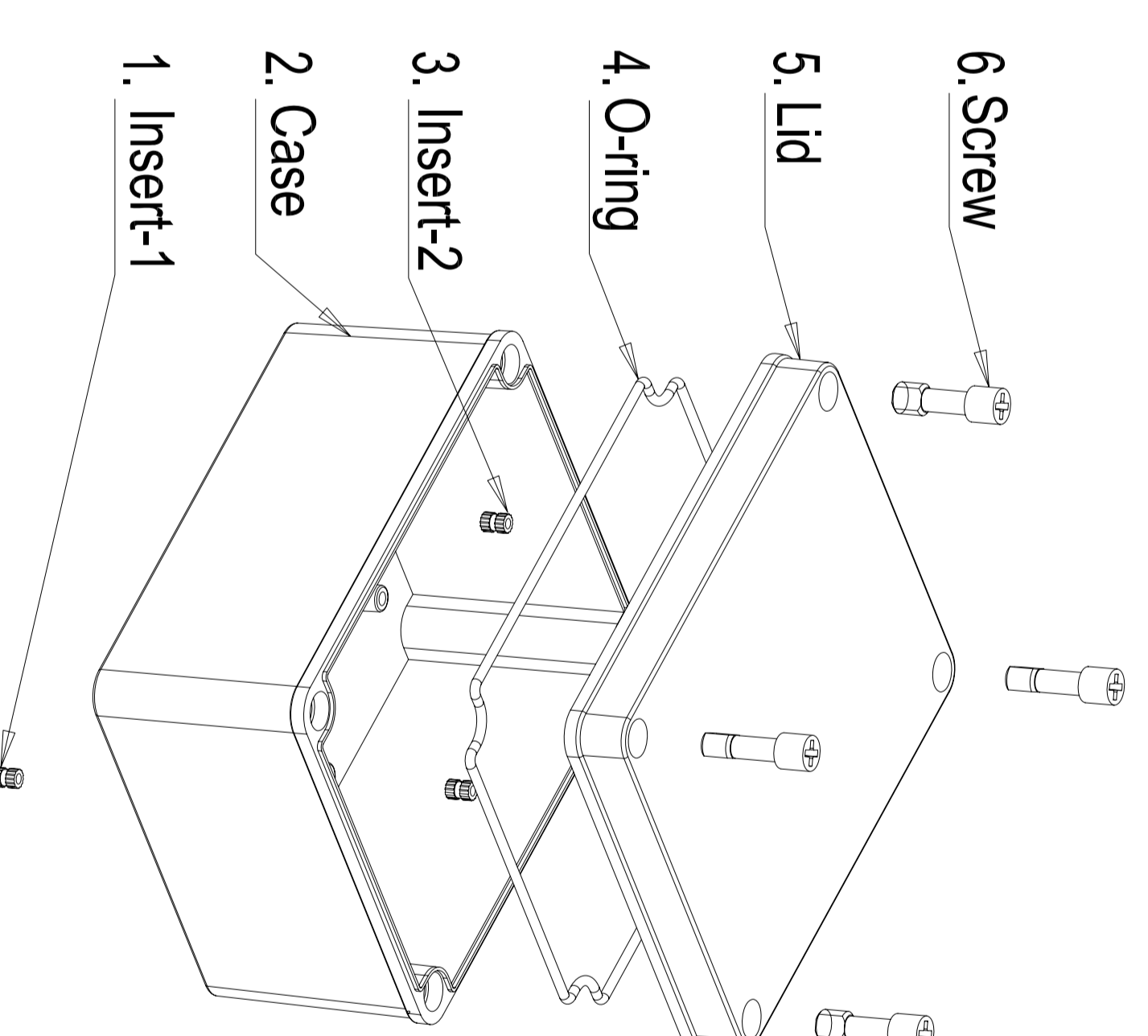

No.	Name	Qty.	Size	Material
6	Screw	4	M10X40	ABS
5	Lid	1	170X140X20	ABS
4	O-ring	1	Ø4X610	PU
3	Insert-2	4	M4X8	Brass
2	Case	1	170X140X76	ABS
1	Insert-1	2	M4X8	Brass

Tolerances: DIN16901 - 130

Treatment:

Scale: Free
 Volume: mm³
 Weight: 0.38 Kg

Original Material:

ABS

Chinese Material:



Metal Processing Co., Ltd

Part Name :

FUP 170 X 140 X 095

Drawing Number :

FUP 170 X 140 X 095

Designer

Liu Junbin 2009.12.17

Technician

Quality department

Sheet

1 of 1

Index (Customer)

REV

Name

Date

Index (FUXIN)

REV

Name

Date

Part Name :
FUP 170 X 140 X 095

Scale: Free
Volume: mm³
Weight: 0.38 Kg

Original Material:

ABS

Chinese Material:

Drawing Number :

FUP 170 X 140 X 095

Designer

Liu Junbin 2009.12.17

Technician

Quality department

Sheet

1 of 1