

NOTICE

1. * Measures are reduced to below because the draft tolerance after GTA13/5 DIN16901-130;
2. Unmarked Draft 2°.

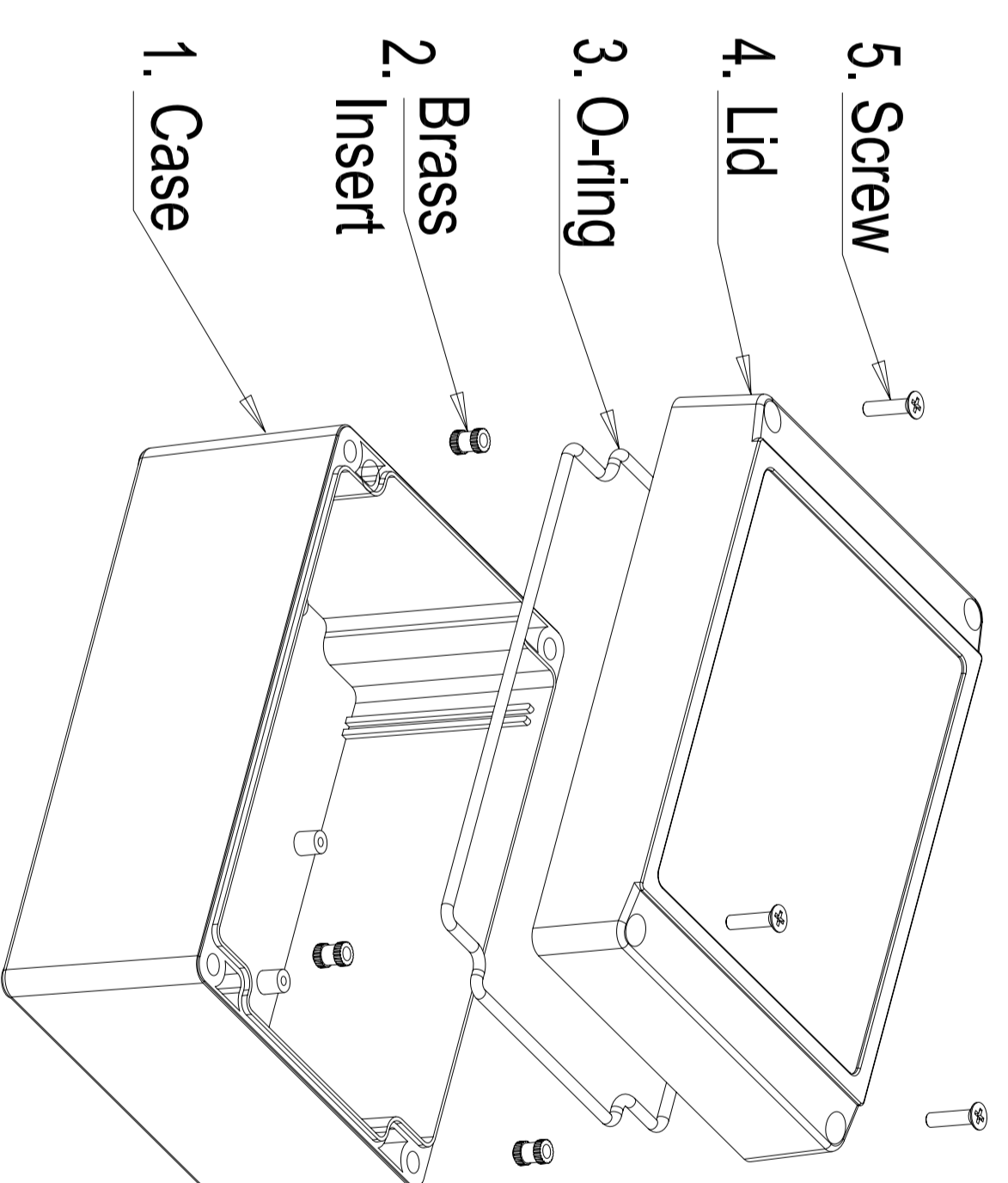

No.	Name	Qty.	Size	Material
5	Screw	4	M4X20 (DIN 965)	Stainless Steel
4	Lid	1	160X111X29	ABS
3	O-ring	1	Ø3X530	PU
2	Insert	4	M4X8	Brass
1	Case	1	160X111X62	ABS

Tolerances: DIN16901 - 130

Treatment:

Scale: Free
Volume: mm³
Weight: 0.294 Kg

Original Material: ABS

Chinese Material:



Metal Processing Co., Ltd

Part Name :

FUP 160 X 110 X 090

Drawing Number :

FUP 160 X 110 X 090

Designer Liu Junbin 2009.12.11

Technician

Quality department

Sheet 1 of 1

Index (Customer)

REV

Name

Date

Index (FUXIN)

REV

Name

Date