

NOTICE
 1. * Measures are reduced to below because the draft tolerance after GTA13/5 DIN16901-130;
 2. Unmarked Draft: 2°.

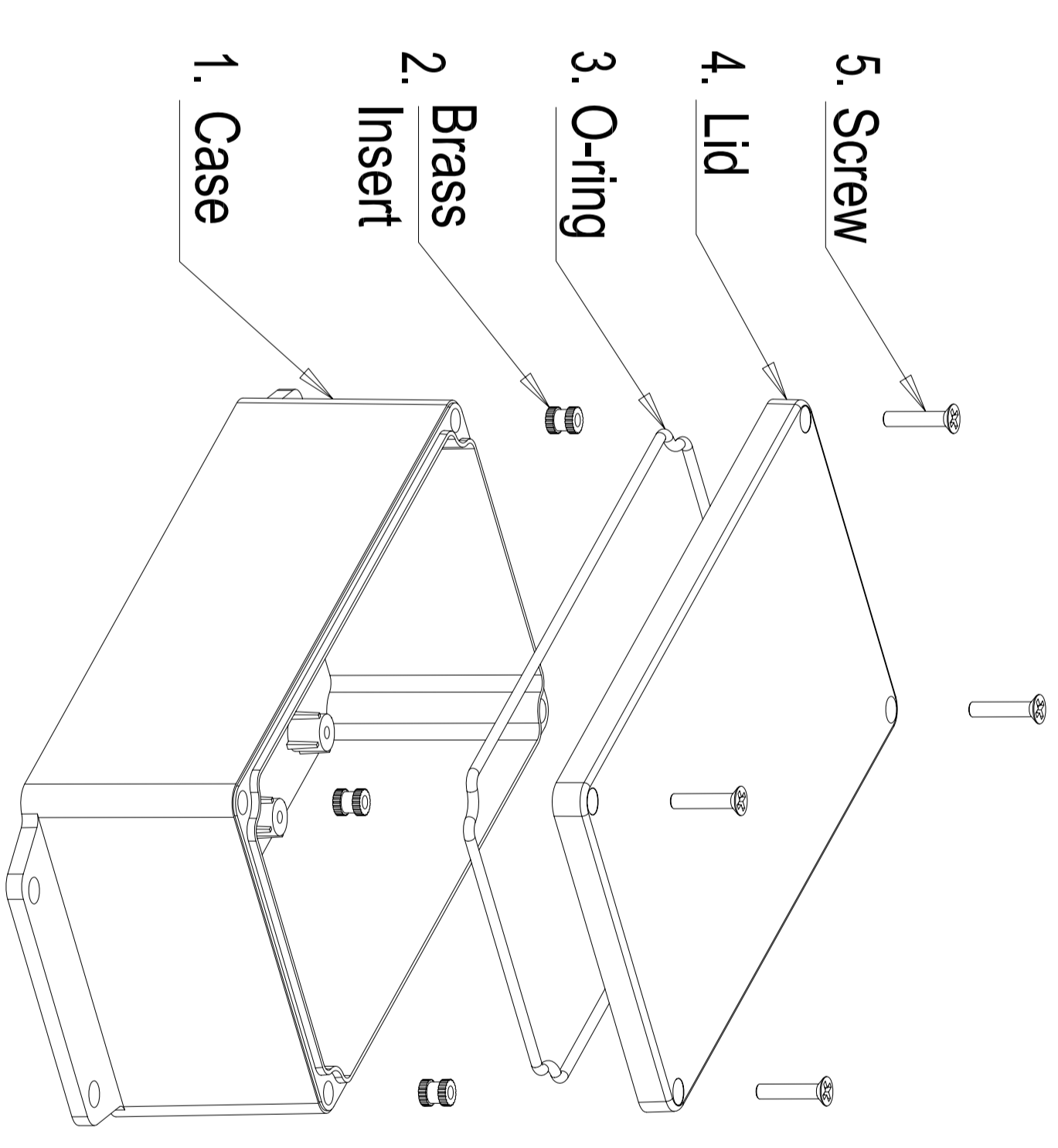

No.	Name	Qty.	Size	Material
5	Screw	4	M4X20 (DIN 965)	Stainless Steel
4	Lid	1	130X75X6.6	ABS
3	O-ring	1	Ø3X400	PU
2	Insert	4	M4X8	Brass
1	Case	1	130X75X45	ABS

Scale: Free
 Volume: mm³
 Weight: 0.126 Kg
 Original Material: ABS
 Chinese Material: ABS
 Tolerances: DIN16901 - 130
 Treatment:

Index (Customer)
 REV
 Name
 Date

Index (FUXIN)
 REV
 Name
 Date

FUXIN
 Metal Processing Co., Ltd

Part Name :
 FUP 130 X 075 X 050

Drawing Number :
 FUP 130 X 075 X 050

Designer: Liu Junbin
 Date: 2009.12.28

Technician
 Quality department
 Sheet 1 of 1