

NOTICE
 1. * Measures are reduced to below because the draft tolerance after GTA13/5 DIN16901-130;
 2. Unmarked Draft 2°.

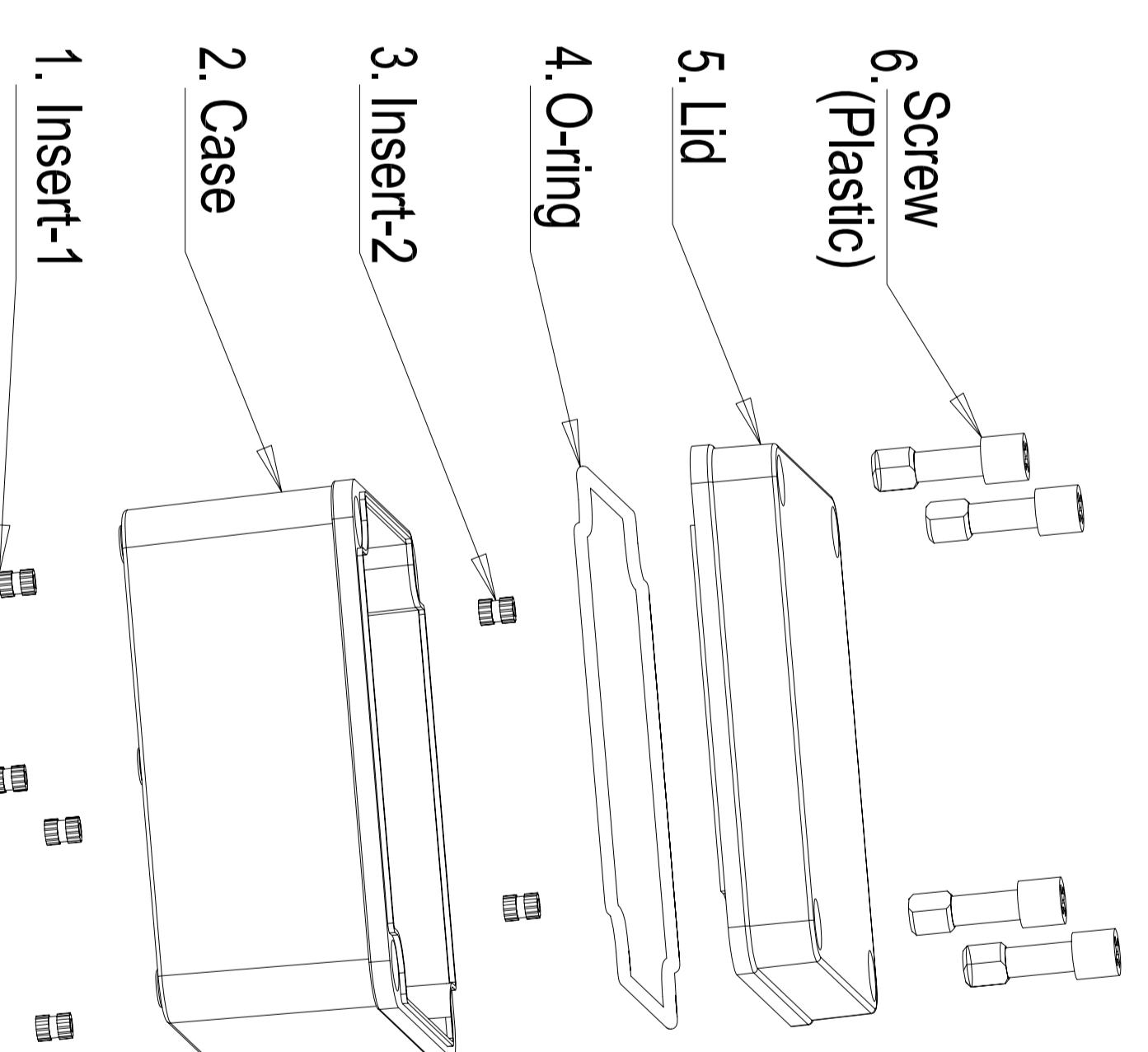

No.	Name	Qty.	Size	Material
6	Screw	4	M10X40	Plastic
5	Lid	1	125X125X20	ABS
4	O-ring	1	Ø3X490	PU
3	Insert-2	2	M4X8	Brass
2	Insert-1	4	M4X8	Brass
1	Case	1	125X125X57	ABS

Scale: Free
 Volume: mm³
 Weight: 0.116 Kg

Original Material: ABS
 Chinese Material:

Tolerances: DIN16901 - 130

Treatment:



Metal Processing Co., Ltd

Part Name :

FUP 125 X 125 X 076

Drawing Number :

FUP 125 X 125 X 076

Designer Liu Junbin 2009.12.08

Technician

Quality department

Sheet 1 of 1

Index (Customer)

REV

Name

Date

Index (FUXIN)

REV

Name

Date