

NOTICE

1. * Measures are reduced to below because the draft tolerance after GTA13/5 DIN1688;
2. Surface Treatment : Powder Coating ;
3. Mounting Plate with Zn-Plated;
4. Unmarked Draft 2°.

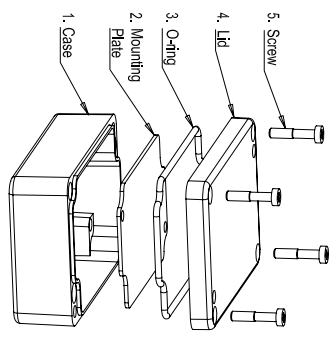

No.	Name	Qty.	Size	Material
5	Screw	4	M4X20 (DIN 955)	Stainless Steel
4	Lid	1	98X64X9	GD AISI 12
3	O-ring	1	Ø3X310	PU
2	Mounting plate	1	88X64X1.5	Al 6063
1	Case	1	98X64X26.5	GD AISI 12

Index (Customer)	REV	Name	Date	Index (FUJIN)	REV	Name	Date

FUJIN
Metal Processing Co., Ltd

Part Name :
FUD - 098 X 064 X 034

Scale: Volume: 0.263 kg
Original Material: GD AISI 12
Chinese Material:

Drawing Number :
FUD - 098 X 064 X 034

Tolerances: DIN1688 GTA13/5
Treatment: Powder Coating

Designer: Liu Junbin
Technician: 2009.12.04
Quality department: Sheet 1 of 1