

NOTICE

1. * Measures are reduced to below because the draft tolerance after GTA13/5 DIN1688;
2. Surface Treatment : Powder Coating ;
3. Mounting Plate with Zn-Plated;
4. Unmarked Draft 2°.

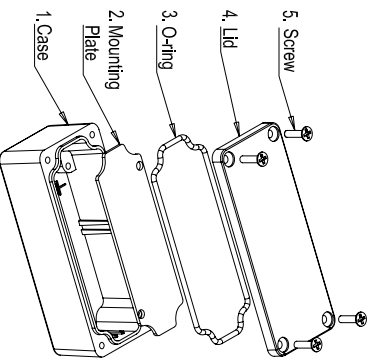

No.	Name	Qty.	Size	Material
5	Screw	4	MAX20 (DIN 965)	Stainless Steel
4	Lid	1	90X36X5	GD AISI 12
3	O-ring	1	Ø3X240	PU
2	Mounting plate	1	68X24X1.5	Al 6063
1	Case	1	90X36X26.5	GD AISI 12

Index (Customer)	REV	Name	Date	Index (FUJIN)	REV	Name	Date

FUJIN
Metal Processing Co., Ltd

Part Name : **FUD - 090 X 036 X 031**

Scale: Volume: mm³
Weight: 0.135 Kg

Original Material: GD AISI 12

Chinese Material:

Drawing Number : **FUD - 090 X 036 X 031**

Tolerances: DIN1688 GTA13/5

Treatment: Powder Coating

Designer: Liu Junbin

Technician: Quality department

2009.12.04

Sheet 1 of 1