

- NOTICE**
1. * Measures are reduced to below because the draft tolerance after GTA13/5 DIN1688;
 2. Surface Treatment : Powder Coating ;
 3. Mounting Plate with Zn-Plated;
 4. Unmarked Draft 2°.

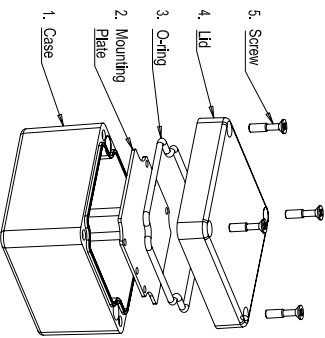

No.	Name	Qty.	Size	Material
5	Screw	4	M4X20 (DIN 965)	Stainless Steel
4	Lid	1	80X75X15	GD AISI 12
3	O-ring	1	Ø3X290	PU
2	Mounting plate	1	67X62X1.5	Al 6063
1	Case	1	80X75X43.5	GD AISI 12

Index (Customer)	REV	Name	Date

Index (FUJIN)	REV	Name	Date

Scale:	Volume:
Original Material:	Weight:
Chinese Material:	

Tolerances:	
Treatment:	

FUJIN
Metal Processing Co., Ltd

Part Name :

FUD - 080 X 075 X 057

Drawing Number :

FUD - 080 X 075 X 057

Designer	Liu Junbin	2009.12.03
Technician		
Quality department		
Sheet of		1/1