

NOTICE

1. * Measures are reduced to below because the draft tolerance after GTA13/5 DIN1688;
2. Surface Treatment : Powder Coating;
3. Mounting Plate with Zn-Plated;
4. Unmarked Draft 2°.

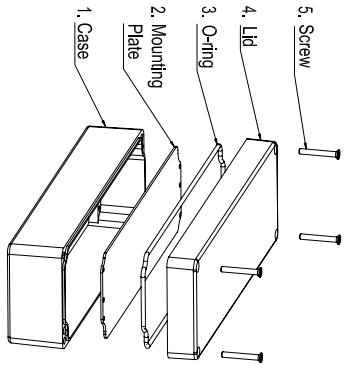

No.	Name	Qty.	Size	Material
5	Screw	4	M4X20 (DIN 965)	Stainless Steel
4	Lid	1	250X80X22	GD AISI 12
3	O-ring	1	Ø3X640	PU
2	Mounting plate	1	237X67X1.5	Al 6063
1	Case	1	250X80X43.5	GD AISI 12

Index (Customer)	REV	Name	Date	Index (FUJIN)	REV	Name	Date

FUJIN
Metal Processing Co., Ltd

Part Name :
FUD - 250 X 080 X 064

Scale: Volume: 0.42 mm³ kg
Original Material: GD AISI 12
Chinese Material:

Drawing Number :
FUD - 250 X 080 X 064

Tolerances: DIN1688 GTA13/5
Treatment: Powder Coating

Designer: Liu Junbin
Technician: 2009.12.05
Quality department: 1 / 1
Sheet of