

NOTICE

1. * Measures are reduced to below because the draft tolerance after GTA13/5 DIN1688;
2. Surface Treatment : Powder Coating ;
3. Mounting Plate with Zn-Plated;
4. Unmarked Draft 2°.

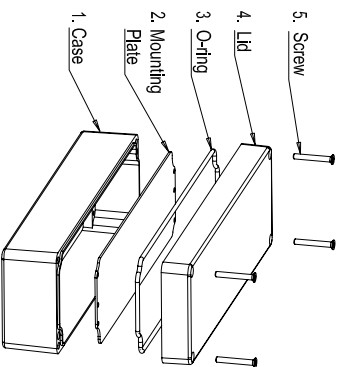

No.	Name	Qty.	Size	Material
5	Screw	4	M4X20 (DIN 965)	Stainless Steel
4	Lid	1	110X64X10	GD AISI 12
3	O-ring	1	Ø3X330	PU
2	Mounting plate	1	98X52X1.5	AI 6003
1	Case	1	110X64X30.5	GD AISI 12

Index (Customer)	REV	Name	Date	Index (FUJIN)	REV	Name	Date



Metal Processing Co., Ltd

Part Name :

FUD - 110 X 064 X 038

Scale: Volume: 0.363 kg

Original Material: GD AISI 12

Chinese Material:

Drawing Number :

FUD - 110 X 064 X 038

Tolerances: DIN1688 GTA13/5

Treatment: Powder Coating

Designer Liu Junbin 2009.12.05

Technician Quality department Sheet 1 of 1